

KLEIN®



About us

We are experts in the design and manufacturing of systems for sliding and folding partitions and doors. Our values are rooted in continuously striving for excellence, and thus ensuring that our customers are extremely satisfied with the quality, design, functionality and service that we offer.

We support professionals working in the fields of architecture and construction by being involved in their projects from the start and providing them with applications that allow them to create unique and versatile spaces with complete conceptual freedom.

**+
85**

**YEARS
EXPERIENCE**



**NETWORK
WORLDWIDE**

5

**YEARS
WARRANTY**

Always Better Since 1931

Our professional experience dates back to 1931, the year that our company was founded. Since then, we have continued to evolve, combining our artisanal craft with the most innovative production systems. The small workshop where we started has grown into an international company, with a subsidiary in the United States.

The values that have guided us to where we are today are still as present as ever: our relentless pursuit of excellence, commitment to investing in research, development and innovation, and active incorporation of ideas from professionals in the architecture and construction fields have laid the foundation for KLEIN's global success and continue to lead us on our path forward.



Research & Development

Our R+D+i department is at the core of our new product design and creation process, guardians of the brand's extremely high standards. We carry out all phases of design, 3D modeling, prototyping and testing at our facilities in Barcelona, as well as the manufacturing of all our products.

Our systems are exclusively produced with European-made aluminum. After being tested to over 100,000 cycles, all of our systems exceed the EN 1527 standard and come with a 5-year warranty.

We are proud of our customers and suppliers' international recognition, as well as the backing we have received from leading international certification organizations and design entities.

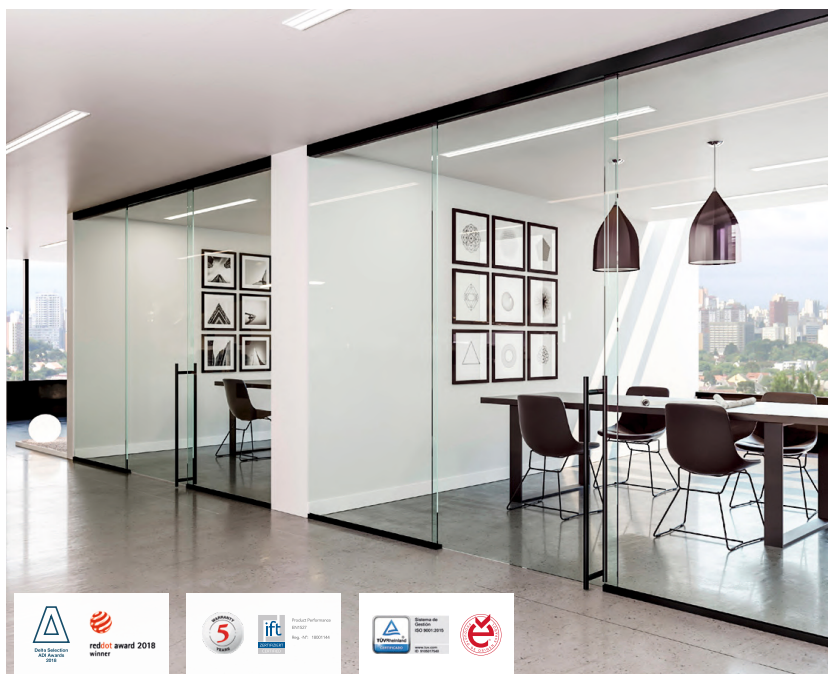

Light

We use natural light, a source of life and joy, as a creative element, turning it into a transformative architectural tool capable of creating spaces full of strength and modernity.

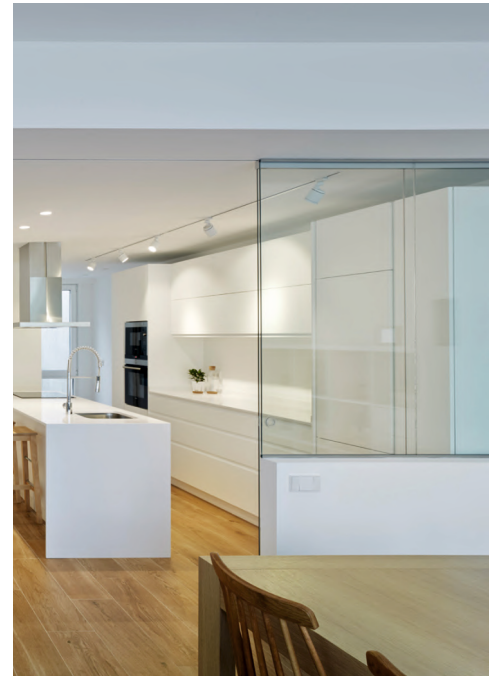
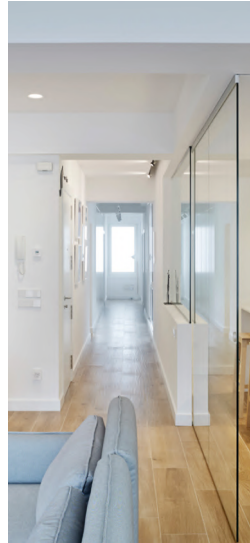

Balance

Our systems make the concept of spatial fluidity a reality: they are rooted in elements of connection, balance and visual harmony.

Movement

We generate dynamic spaces, capable of being transformed through organic movement that respects the rhythms of life.



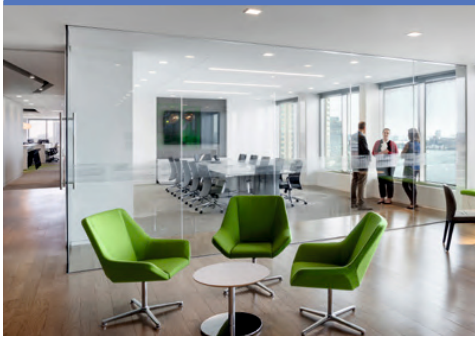

Unique Interiors

We combine light and movement to create balance in interior spaces. We innovate to design sliding and folding applications that allow architects to connect, open up and create comfortable and beautiful rooms.

Innovate with Meaning

KLEIN systems are designed to add value to interior design projects: total architectural integration, limitless project creativity, a variety of finishes, and easy installation and maintenance. The highest quality, down to the smallest detail.



reddot award 2018
winner



Delta Selection
ADI Awards
2018



Product Performance
EN1527
Reg.-Nº: 19001144



News 2019

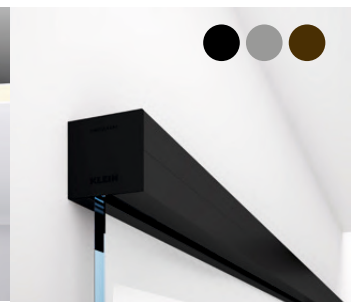
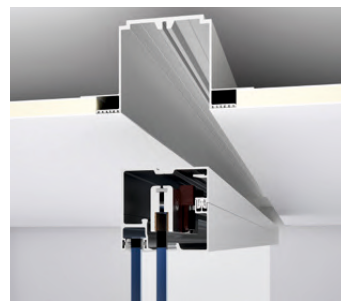

New Front & LigneA

Our new FRONT and LIGNEA systems create beautiful spaces by combining fixed glass panels with sliding wood doors, both located on a single profile. Every last detail counts when striving for perfection and customization

KSC-Klein Soft Closing

Our own braking device, tested to 100,000 cycles in accordance with the EN 1527 standard and certified by the seal of the IFT. Cutting-edge technology for glass and wood applications. Comfort and safety for the user.

Recessed Frame Track

Total architectural integration. Its easy installation, carried out in two phases, guarantees maximum efficiency and the invisibility of the system.

New Black And Bronze Matte Finishes

Customization and character for one-of-a-kind projects. Trends combined with elegance.





Glass: Transparency and freedom

SPACES WITHOUT BORDERS

Freedom to connect, open up or create spaces, without barriers. Although glass is pure transparency, it becomes the protagonist of the architecture, boosting natural light and playing with shadows. Our systems allow its spectacular beauty to be put on display with absolute simplicity. Without frames. Without floor tracks. Less is more.



The new KLEIN+ clamp fastens the glass with pressure, doing away with the need for frames and drilling. Without any floor tracks, the laminated or tempered glass seems to float, sliding along smoothly, regardless of its size.

PRODUCT	WEIGHT*	BRAKE			MOUNTING		
	KG.	KBS	KSC	SELF	WALL	CEILING	RECESSED
 ROLLGLASS+	50/100/150	●	●			●	●
 UNIKGLASS+	100	●	●		●	●	●
 LITE GLASS +	100		●		●	●	●

* The weight is calculated based on the following formula: Height [m] x Width [m] x Thickness [mm] x 2,5 = Weight [kg]



Product Performance
EN1527
Reg.-N°: 18001144



reddot award 2018
winner



Rollglass+

Rollglass+ creates a glass front that combines fixed and mobile glass panels on a single track. It can be hidden in a drop ceiling for a completely minimalist effect, with a recessed frame track that allows for a phased installation. Versatile and flexible, it allows for various combinations, and is precise down to the smallest detail.

Available with or without a bottom profile for the fixed glass. Easy installation (for Rollglass+ 50/100).

Door braking systems available:

KSC - Klein Soft Closing, smooth, controlled closing.

KBS - Klein Brake System, stop with damper brake available for Rollglass+ 50/100.

● Alu. Silver Matte

	50 kg
Max. weight:	100 kg
	150 kg
Brake:	KSC

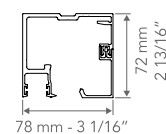



ROLLGLASS+ 50/100

ROLLGLASS+ 150

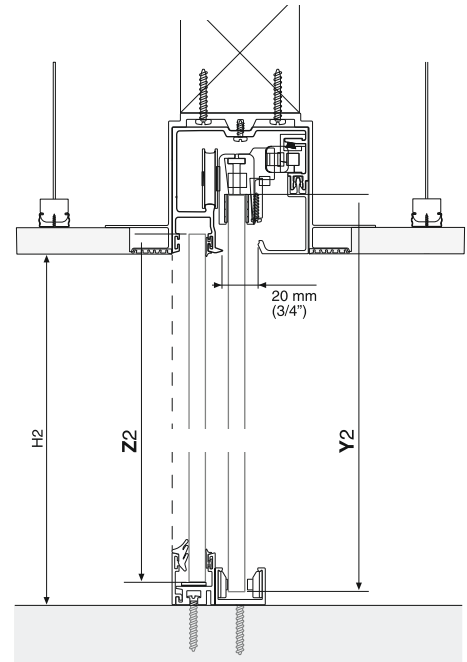
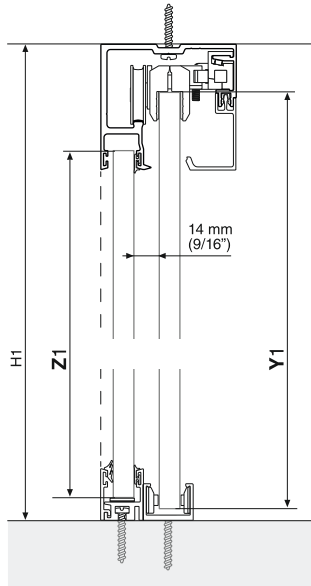
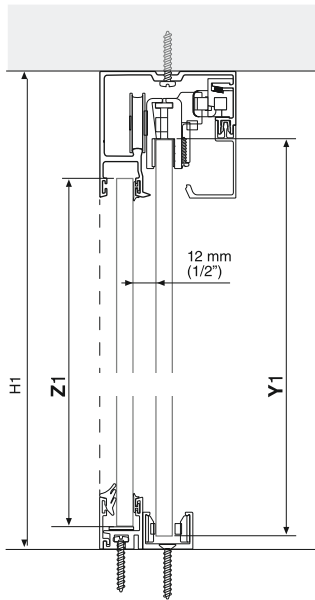

$Y1 = H1 - 47 \text{ mm (1 13/16")}$
 $Z1 = H1 - 74 \text{ mm (2 7/8")}$

$Z1 = H1 - 74 \text{ mm (2 7/8")}$
 $Y1 = H1 - 35 \text{ mm (1 3/8")}$

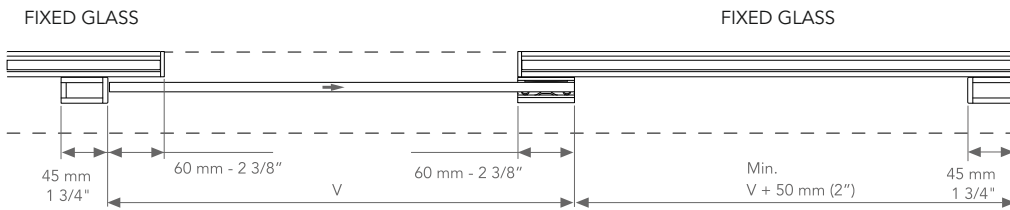

ROLLGLASS+ 50/100 KSC: $V \geq 800 \text{ mm (31 1/2")}$
 ROLLGLASS+ 150 KSC: $V \geq 1.000 \text{ mm (39")}$





Product Performance
EN1527
Reg.-Nº: 18001144



Unikglass+

Unikglass+ connects rooms with a single sliding glass panel. Restrained and discreet, it saves space and adds modernity. It can be hidden in a drop ceiling for a completely minimalist effect, with a recessed frame track profile that allows for a phased installation. The beauty of simplicity.

Easy installation (for Unikglass+ 50/100).

Door braking systems available:

KSC - Klein Soft Closing, smooth, controlled closing.

KBS - Klein Brake System, stop with damper brake available for Unikglass+ 50/100

 Alu. Silver Matte

Max. weight:	50 kg
	100 kg
	150 kg
Brake:	KSC KBS*

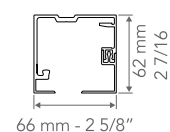



EXPOSED

UNIKGLASS+ 50/100

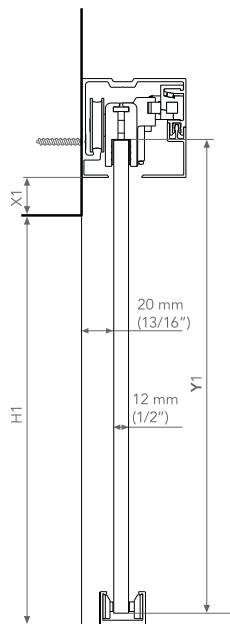

$Y1 = H1 + X1 + 16 \text{ mm (5/8")}$

UNIKGLASS+ 150

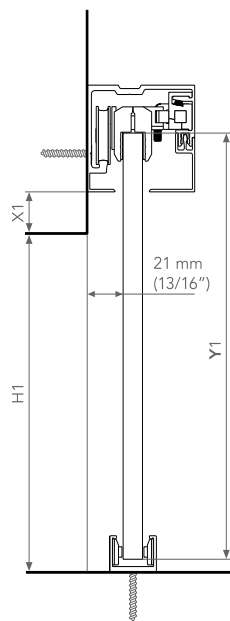

$Y1 = H1 + X1 + 27 \text{ mm (1 1/16")}$

RECESSED

WITH LINTEL

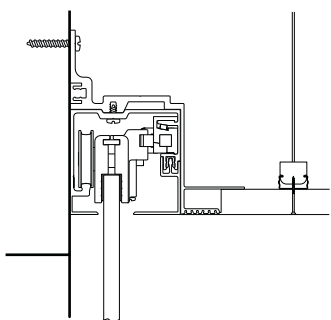

WITHOUT LINTEL

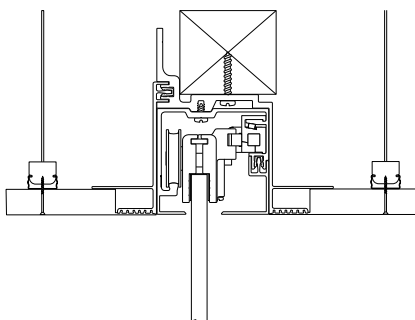

WITHOUT LINTEL

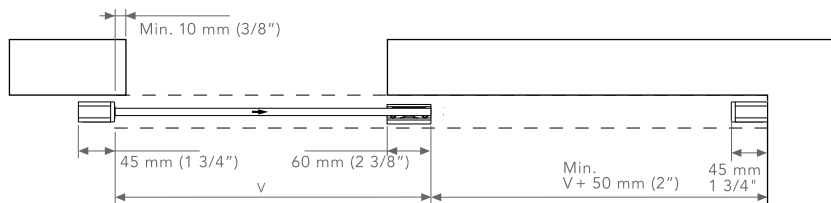
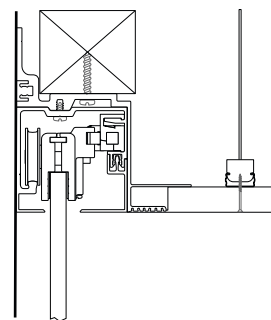

UNIKGLASS+ 50/100 KSC: $V \geq 800 \text{ mm (31 1/2")}$
 UNIKGLASS+ 150 KSC: $V \geq 1.000 \text{ mm (39")}$





Lite Glass+

The **Lite Glass/Lite Glass+** line connects rooms with a sliding door. It offers numerous configurations, such as bi-passing or bi-parting doors.

Its Top profile allows the profile to be recessed in a drop ceiling.

Optional braking system with Lite Glass+ 100: **KSC** - Klein Soft Closing, smooth, controlled closing.

● Alu. Silver Matte

Max. weight:	100 kg
Brake:	KSC

LITE GLASS / LITE GLASS+ 100

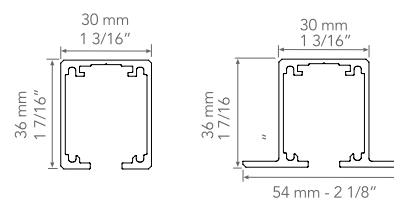

LITE GLASS / LITE GLASS+ 100

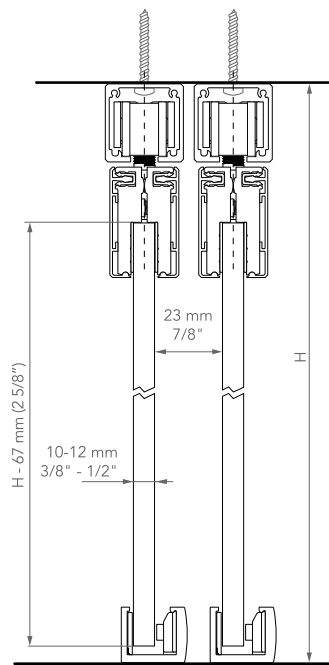

PERFIL TOP / TOP TRACK

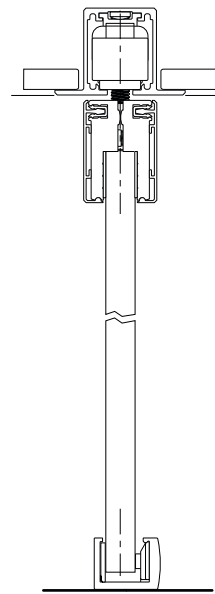



Wood: Warmth and customization



SPACES IN MOVEMENT

Are they doors or partitions? Do they connect or transform spaces? They are a world of possibilities.

Mobile wood panels create flexible rooms in which the interior woodwork becomes the protagonist. The beauty and elegance of this material, as well as the variety of finishes and sizes available, allow your creativity to flourish.

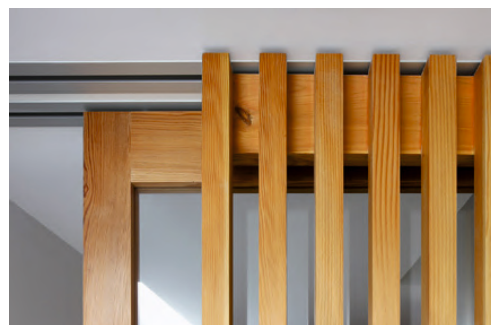
Floor-to-ceiling wood, without floor tracks, slides along smoothly, transforming its surroundings as if through magic. Spectacular sizes that increase and enhance the quality of the space.



PRODUCT	WEIGHT*	BRAKE			MOUNTING		
	Kg.	KBS	KSC	SELF	WALL	CEILING	RECESSED
 LITE+	100		●		●	●	●
 SLID	150				●	●	●

* The weight is calculated based on the following formula: Height [m] x Width [m] x Thickness [mm] x Density = Weight [kg]





Lite+

The **Lite / Lite+** line connects rooms with a sliding wood panel. It offers numerous configurations, such as bi-passing or bi-parting doors. There are two types of fittings: Superior (exposed) and Retrac (hidden in the panel). The Top version allows the profile to be recessed in a drop ceiling.

Mobile partitions that transform interior spaces.

Optional braking system for Lite+ 100:
KSC - Klein Soft Closing, smooth, controlled closing.

 Alu. Silver Matte

Max. weight:	100 kg
Brake:	KSC

LITE / LITE+ 100

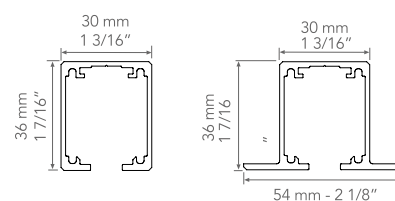

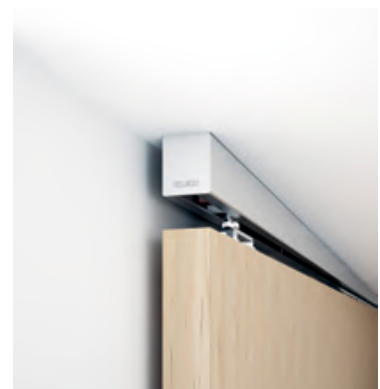
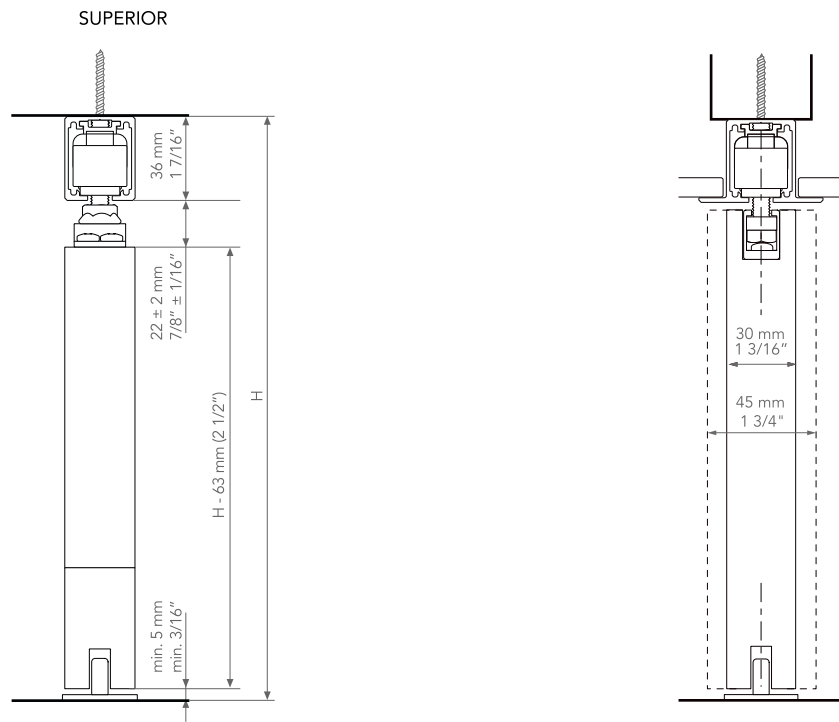



Slid

Slid is designed to divide spaces with wood or metal panels. Smooth, effortless sliding.

It offers numerous configurations, such as bi-passing, bi-parting doors or corner doors. There are two types of fittings: Superior (exposed) and Retrac (hidden in the panel). The Top profile allows the profile to be recessed in the drop ceiling. The Intra version allows the panel to be installed between walls.

Mobile partitions that transform interior spaces.

 Alu. Silver Matte

Max. weight: **150 kg**

SLID 150

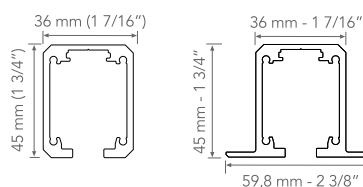

SLID 150

SUPERIOR

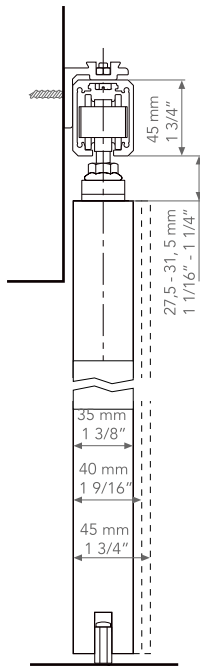

RETRAC

